

## METALS RECOVERY SYSTEM

The Metal Recovery System is an ion exchange resin based solution, this system operates on a semi-continuous, batch mode, basis, and is capable of reliably processing metal containing wastewater with greater than 95% recovery of the metal. Resin regeneration may be operator initiated at any time. The system is designed to require minimal maintenance.

The system is typically operated with metal absorption vessels in a lead/lag configuration. Metal, such as copper, is removed from the wastewater in a process termed CRV or Copper Recovery Vessel.



### Definition:

Metal absorption is the process of exchanging metal ions in wastewater for ions that are chemically bonded to the solid polymeric ion exchange resin material. Ion exchange resins are generally in a bead form, which has charged functional groups built into the polymer structure. These functional groups “hold” ions of opposite charge by electrostatic attraction. Ion exchange occurs because the functional groups have a greater affinity for the metal ions in solution than for the ions that are attached to the polymer’s functional groups. The recovery vessel uses a metal selective ion exchange media. For example, copper ions present in the wastewater selectively attach to the ion exchange resin polymer functional groups.

### Regeneration Process:

When the ion exchange resin is converted to the copper form, it requires regeneration. Regeneration is the process of removing the copper ions from the ion exchange resin by “reversing” the ion exchange process. The “reversing” of the ion exchange process is accomplished by passing a concentrated solution of acid through the ion exchange resin. As shown in the photo, the recovered copper solution becomes darker (more concentrated with copper) as the regeneration proceeds.



### System Performance:

The Metal Recovery Vessel (MRV) is capable of reliably processing wastewater on a semi-continuous batch basis. Typical recovery efficiencies and the estimated recovered metal solution analysis are:

**Copper Recovery Efficiency, % > 95**

**Typical Recovered Copper Solution Analysis:**

**Copper, 1-2%**

**Water, 80 -90%**

Process flow Diagram

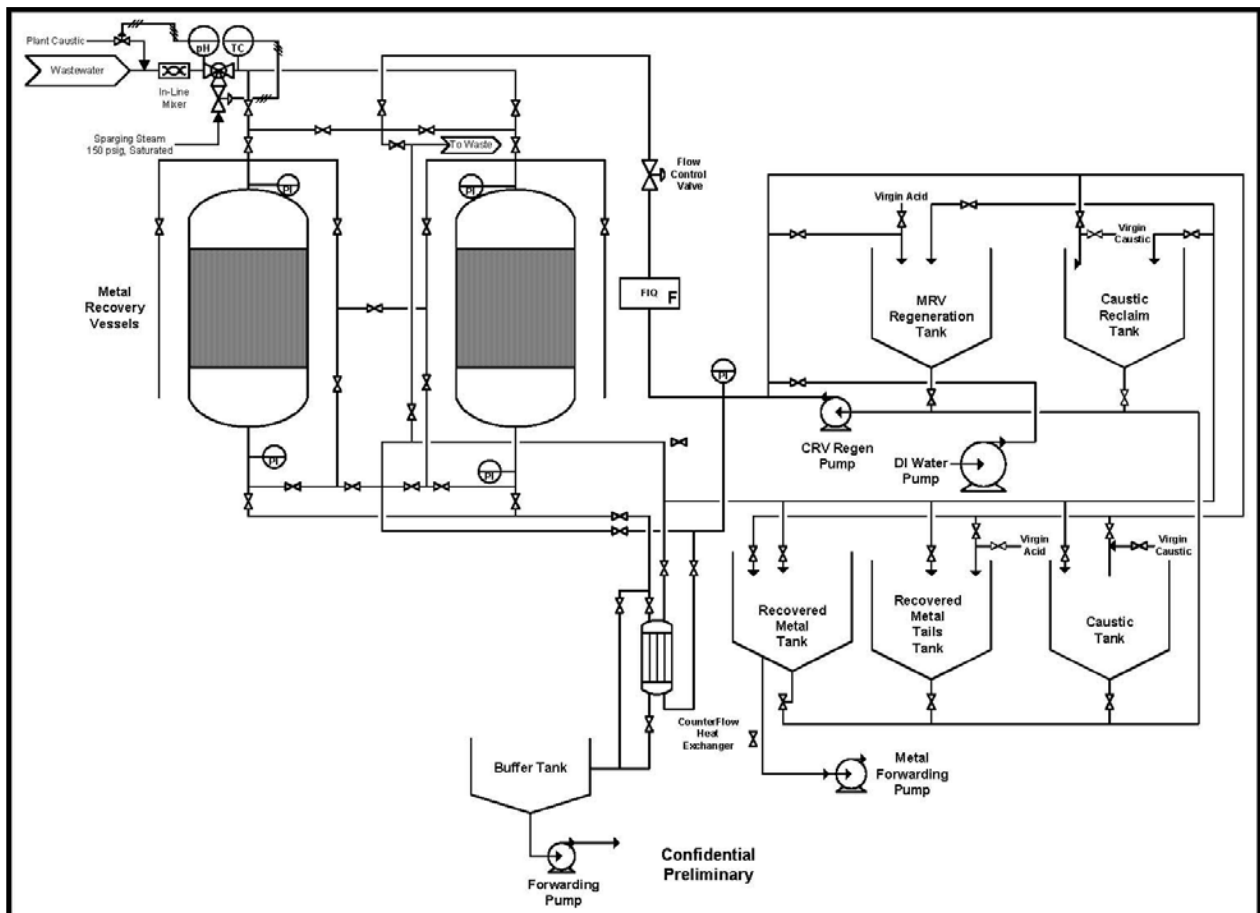

### Learn More

To learn more about our A2/O Conventional Activated Sludge Solution or any of our other wastewater solutions, please visit our web site at [www.lightenvironmental.com](http://www.lightenvironmental.com) or call our Corporate Sales Office at: 1-816-537-9190.

We look forward to providing your next wastewater solution.